



RFS3: 10 MHz Rubidium Oscillator



Key Features

- Rubidium Oscillator for OEM applications
- Ultra low phase noise.
- Ultra low Allan Deviation
- Low monthly and yearly ageing
- External 1 pps conditioning option
- 10 MHz Sinewave Output
- Integrated GPS receiver option
- RS232 interface (control and monitor)
- 12 or 24 VDC Power Supply
- Custom built options available upon request

Description

The RFS3 is a high quality rubidium oscillator module. Intended for OEM applications, the RFS3 provides a very accurate 10 MHz output signal. The RFS3's base plate will need to be placed on a suitable heat sink

A special feature of the RFS3 is the very low phase noise, typically better than -106 dBc/Hz at 1 Hz offset (optional -113 dBc @ 1 Hz offset). This is typically 30 to 40 dB lower than competitive units.

Also the Allan Deviation stability is very low. The entire oscillator is very reliable and has been designed for a 20 year life.

Many options are available for the RFS3 including built in GPS receiver, 12 or 24 V power supply, external 1pps disciplining and lower monthly ageing with higher stability.

The plot below shows the typical phase noise for an optional low phase noise unit.

Typical phase noise for a 10.00 MHz Output

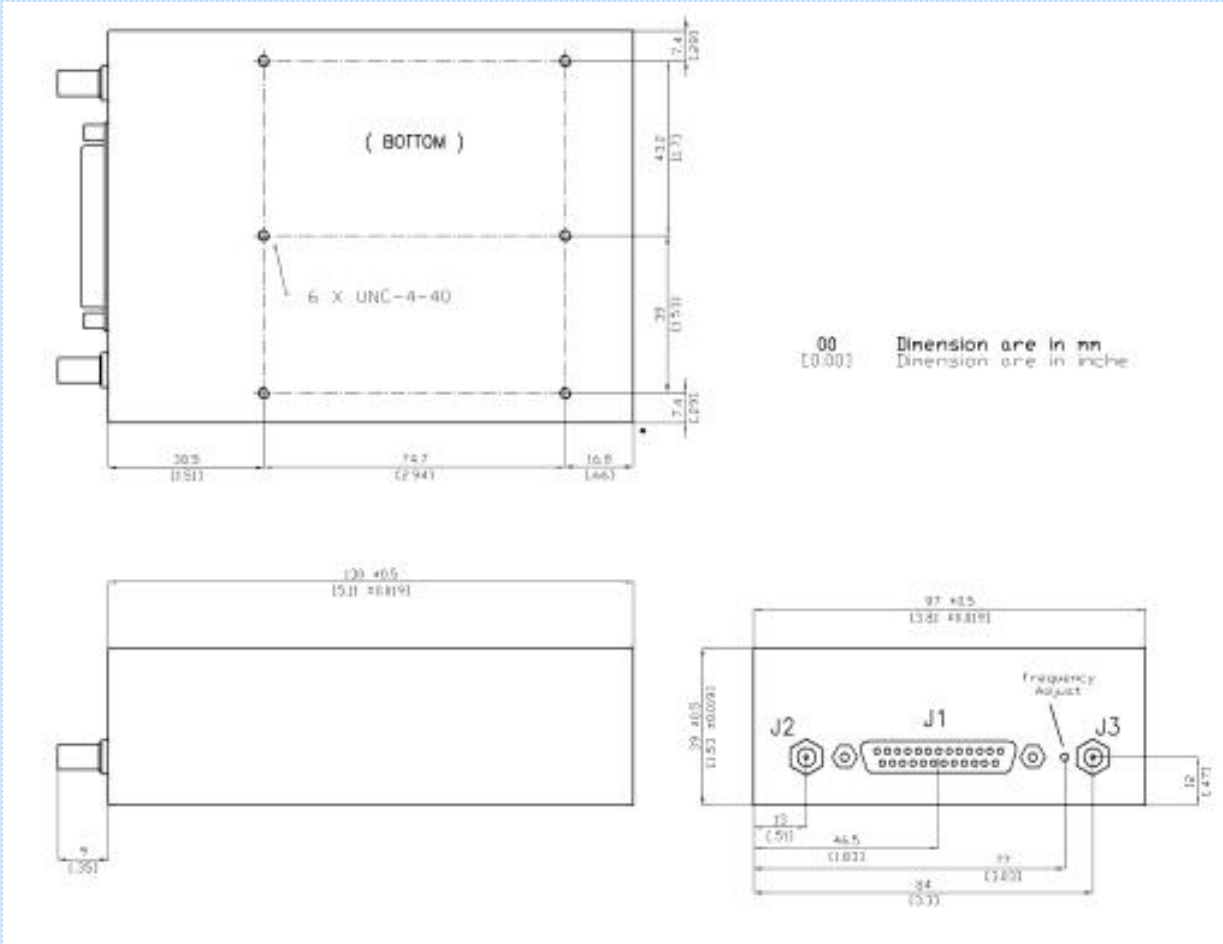
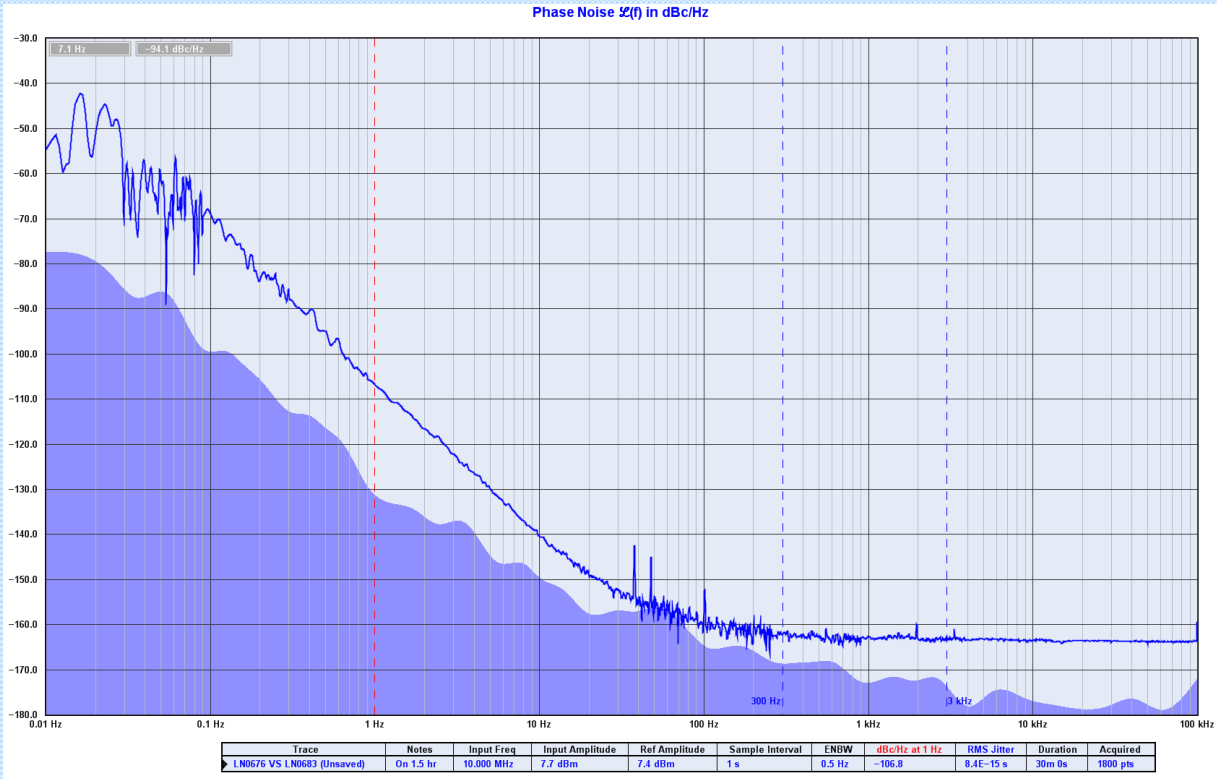

Specifications

Description	Specification	Remarks
Rubidium Oscillator		
Output Frequency	10 MHz sinewave (option squarewave)	Optional change to 5 MHz
Output Level	Sine Wave +7 dBm into 50 Ω	
Aging (after 30 days)	$< 5 \times 10^{-11}$ /month or $< 5 \times 10^{-10}$ /year	Typically 3×10^{-11} /month
Aging (option after 30 days)	$< 3 \times 10^{-11}$ /month or $< 2 \times 10^{-10}$ /year	Typically 1×10^{-11} /month. Opt 03
Accuracy at shipment	$< \pm 5 \times 10^{-11}$ @ 25 °C	
Allan Deviation (standard)	$< 1.5 \times 10^{-12}$ (1s), $< 7.0 \times 10^{-13}$ (100s)	
Allan Deviation (option))	$< 1.2 \times 10^{-12}$ (1s), $< 6.0 \times 10^{-13}$ (100s)	Option 04
Phase Noise (Standard Unit)	-106,-136,-155,-160,-162 dBc/Hz	@ 1/10/100/1k/10k/ Offsets
Phase Noise (Option)	-113,-145,-159,-162,-163 dBc/Hz	@ 1/10/100/1k/10k/ Offsets
Spurious / Harmonics	< -120 dBc (100 kHz BW) / -40 dBc	
Frequency Retrace	$\pm 5 \times 10^{-11}$ (24 hours off, 1 hour on)	Typical
Digital Frequency Adjustment	$\pm 1.6 \times 10^{-8}$ Resolution $< 5.12 \times 10^{-13}$	
Analog Trim Range	$\pm 5 \times 10^{-9}$	
Warm-Up Time	< 12 minutes to within 5×10^{-10}	
Temperature Coefficient	$\pm 1 \times 10^{-10}$ (-10 °C to +55 °C)	Optional < 5 minutes
Magnetic Field	$< 2 \times 10^{-10}$ for 1 Gauss field reversal	Option -32 °C to +65 °C
Design Life	10 to 20 years	
Options		
Option 07	Integrated GPS Receiver	RFS3 disciplined by GPS system
Option 08	10 MHz CMOS Output	
Miscellaneous		
Operating / Storage Temp.	-10 °C to +55 °C / -55 °C to +85°C	Base Plate
Power Supply	+12 VDC (11.2-16V) standard,	Option 20 to 32V
Current	2.5A warm-up, 1 A steady state	Typical
Protection	± 30 VDC on any power pin	
Interface	RS232, 9600 baud 0 to 5V levels	
Lock Indicator	Open Collector	
Operation Vibration	GR-63-Core, Section 5.4.2	Random MIL-PRF-28800F, Class 3,4
Shock	Survival 40g 11 ms	
Helium Concentration Sensitivity	$< 1E-10$ per ppm of Helium concentration	
EMC	MIL-STD-461F/CE-102	
Physical / Weight	128 x 95 x 38.1 mm / 0.24 kg.	
Consult Precision Test Systems for further details of available options.		

Head Office (UK)	South Africa	USA
Precision Test Systems LTD The Studio, Whitehouse Farm, New Hall Lane, Mundon Maldon, Essex, CM9 6PJ, UK Tel: +44 (0) 870 368 9608 Fax: +44 (0) 1245 330030 Email: uksales@ptsyst.com Web: www.ptsyst.com	Precision Test Systems cc Randburg Gauteng South Africa Fax 08651 58198 Email: sasales@ptsyst.com Web: www.ptsyst.com	Precision Test Systems L.L.C 304 S. Jones Blvd Suite #807 Las Vegas, NV, 89107 Tel: 1 888 876 4804 Fax: 1 832 201 6564 Email: usasales@ptsyst.com Web: www.ptsyst.com

Specifications subject to change without notice (240616)